

Fire Alarm Accessories

Zone Interface Module

Model No: ZIM-C-A-01



ANISO9001: 2008COMPANY-



DIMENSION

Width 120 mm, Height 80 mm, Depth 55 mm.

Housing Material: ABS.

Protection: IP 67.

SPECIFICATIONS

SUPPLY

Voltage: 24v DC \pm 6 volts. (110/ 240v Optional)

Stby Current with EOL: 10 mA.

Alarm Current: 80 mA. Max

Fault Current: Open Ckt. 25 mA.

Short Ckt. 120mA.

DETECTORS

40 conventional Detectors Max.

MCP unlimited.

EOL Resistor 4700 ohms.

Alarm resistance. 470 Ohms.

INTERFACE TO MONITOR MODULE

Normal: 47k EOL built in.

Fault : Open Circuit.

Fire Alarm: 1000 ohms.

LED INDICATIONS

5 mm Amber 2 Nos. Detector Circuit

Open / Short circuit Fault indication.

5 mm Red 1 No for Fire Alarm.

Isolation. 1000v min between Detector and Monitor

Module Terminals

Inside View

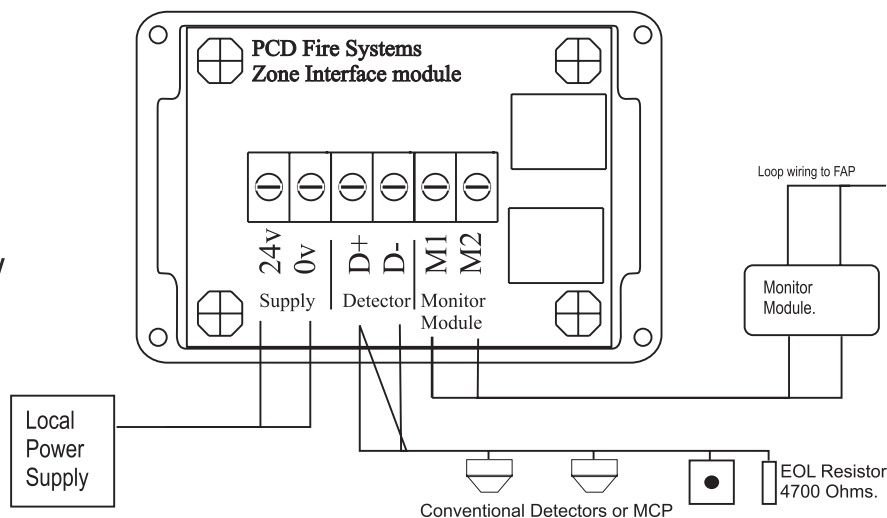

☎ 022 41205036 / 022 25003210 | CEO: Joseph Rozario: 9930533861

✉ sales@pcdfire.co.in info@linovate.in 🌐 www.pcdfire.co.in

Head Office - Ground Floor, C-15 Kailash Esplanade, L.B.S. Marg, Ghatkopar (w), Mumbai 400086

Works - Ghatkopar Industrial Estate, B/h R-City Mall, L.B.S. Marg, Ghatkopar (w), Mumbai 400086

Fire Alarm Accessories

Zone Interface Module

Model No: ZIM-C-A-01



ANISO9001: 2008COMPANY-

Dimensions & Mounting Diagram.

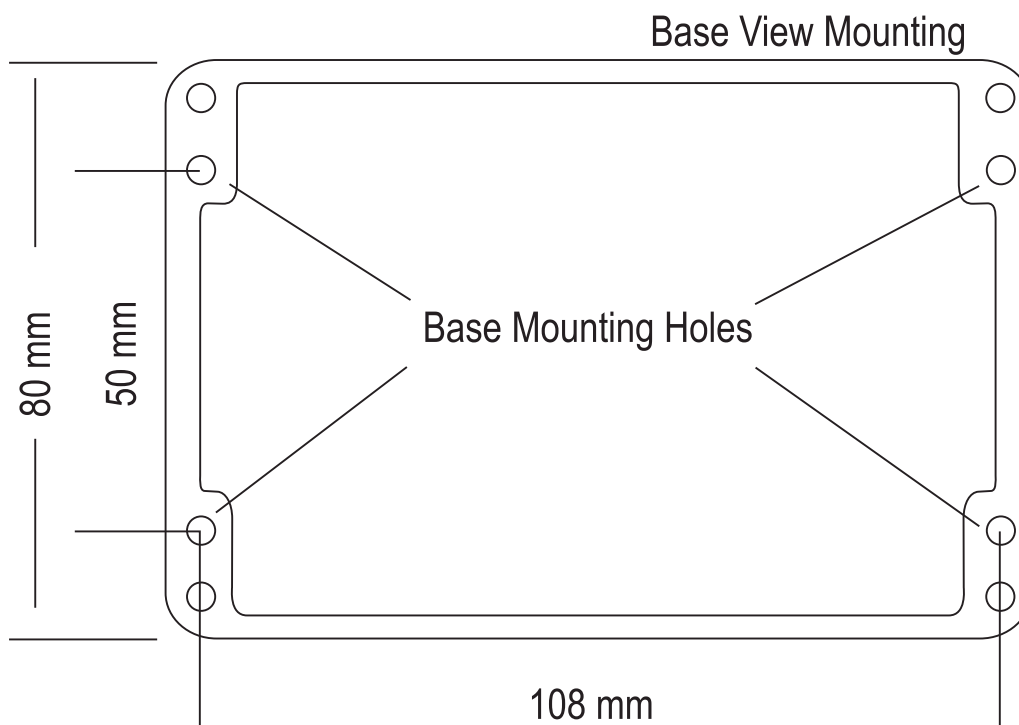
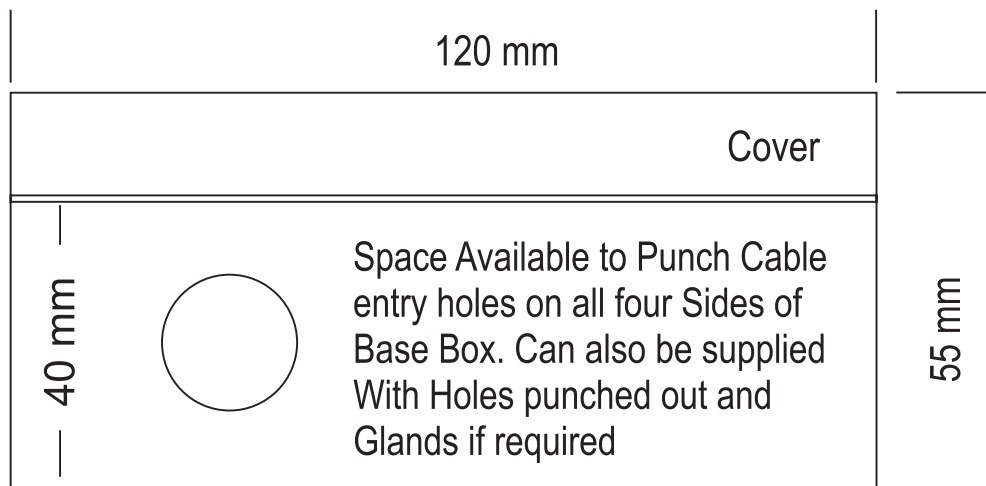

☎ 022 41205036 / 022 25003210 | CEO: Joseph Rozario: 9930533861

✉ sales@pcdfire.co.in info@linovate.in 🌐 www.pcdfire.co.in

Head Office - Ground Floor, C-15 Kailash Esplanade, L.B.S. Marg, Ghatkopar (w), Mumbai 400086

Works - Ghatkopar Industrial Estate, B/h R-City Mall, L.B.S. Marg, Ghatkopar (w), Mumbai 400086