

Fire Alarm Accessories

Probe Type Heat Sensor

Model No- PPS-75FJB/PPS-75



ANISO9001: 2008COMPANY-



PPS-75FJB

Probe Type Heat Sensor is designed to operate at a fixed temperature. This detector finds a suitable application at various places like Kitchen Hoods, Paint Booths, Ducts, Generator Sets, CNC Machines etc. This Heat Sensor is having a Flame Proof Thermocouple Head.

Model No- PPS-75FJB/PPS-75
Upper Rod Dimensions Inner Detail

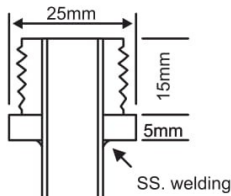

12 OD, 10 ID x 170 mm

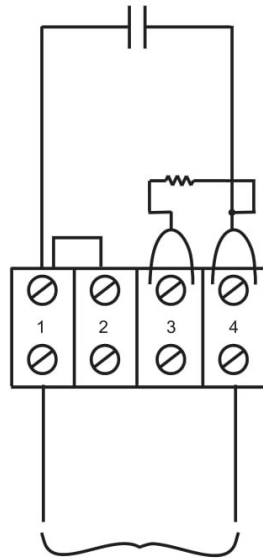

Zone Terminals of the Fire Alarm Panel

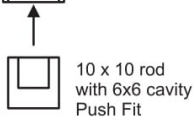

10 x 10 rod
with 6x6 cavity
Push Fit

FEATURES

- High Sensitivity.
- Quick Reaction
- Excellent Reliability
- Long Life
- High Temperature of 75 Degree Celsius

SPECIFICATIONS

- Cable Entry - Two Holes Aside
- Resistance-3 K Ohm
- Storage Temperature- 120 Deg. Celsius
- Maximum Latching Current-3.1 mA
- Sensitivity-70% /Deg. Celsius
- Color- Grey

Specifications

Model No- PPS-75FJB- WITH FLAMEPROOF THERMOCOUPLE HEAD AT BOTTOM

PPS-75- ONLY UPPER ROD

WWW.PCDFIRE.COM - Please Visit Our Website for Other Product Information

022 41205036 | 022 250003210 | 9930533861 | 9920520573 | 9987665570

sales@pcdfire.com | joseph@pcdfire.com | crispin@pcdfire.com

Head Office: Office No E1-110, Kailash Esplanade, LBS Marg, Ghatkopar West, Mumbai – 400 086
Works: Ghatkopar Industrial Estate, B/h R-City Mall, LBS Marg, Ghatkopar West, Mumbai – 400 086

LINOVAE TECHNOLOGIES : Authorized Channel Partners For Pan India & OEM for PCD make Fire Alarm Systems

Pg 1/2

Fire Protection Panel
Alarm Point Locator
 Model No:-LHS-APL



ANISO9001: 2008COMPANY-

Thermocouple Head Dimensions

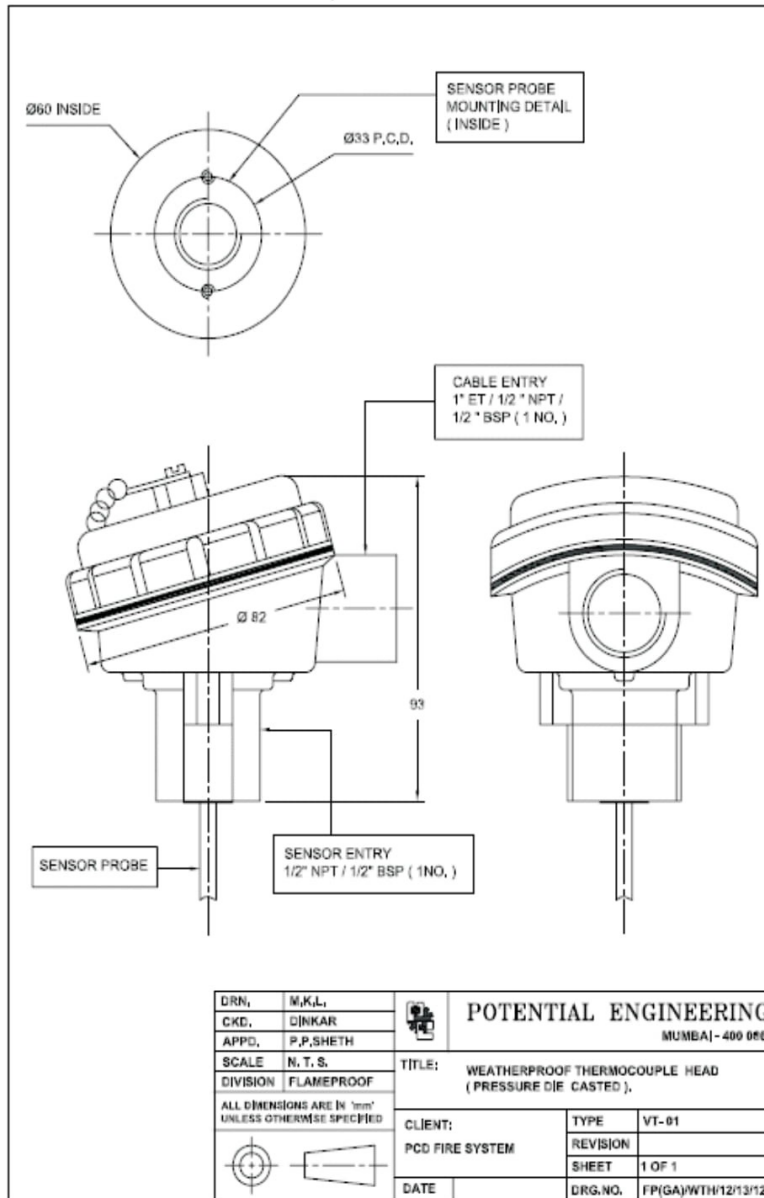

WWW.PCDFIRE.COM - Please Visit Our Website for Other Product Information

022 41205036 | 022 250003210 | 9930533861 | 9920520573 | 9987665570

sales@pcdfire.com | joseph@pcdfire.com | crispin@pcdfire.com

Head Office: Office No E1-110, Kailash Esplanade, LBS Marg, Ghatkopar West, Mumbai – 400 086
 Works: Ghatkopar Industrial Estate, B/h R-City Mall, LBS Marg, Ghatkopar West, Mumbai – 400 086

LINOVATE TECHNOLOGIES : Authorized Channel Partners For Pan India & OEM for PCD make Fire Alarm Systems

Pg 2/2