

Fire Alarm Panel
**Conventional Multi
 Zone Panel**
 (8-16-32 Zone Fire Alarm Panel)
 Model: CD 32-LC

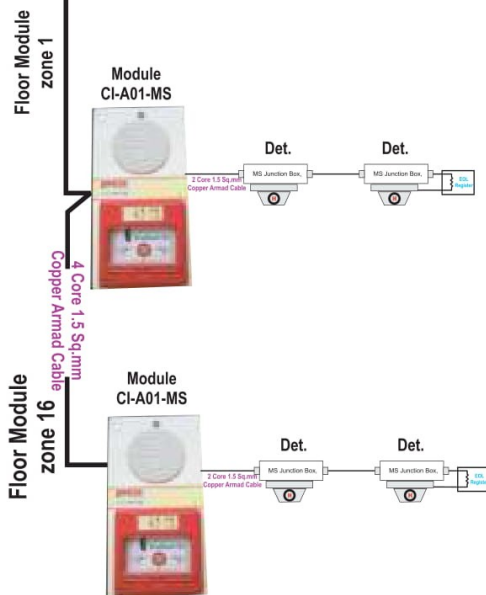

ANISO9001: 2008COMPANY-



Model N0:-CD32 LC-16Z

INTRODUCTION

These are micro controller based master control and display panels. Their Function is to communicate with Addressable Input and Output Modules connected to It via a 2 wire Rs485 Bus. The CD-32 communicates with max32 zone Modules. This Series of fire alarm panels make optimum use of the addressable features to reduce cable cost. This panel is available with LED Fire & Fault Annunciators for 16 or 32 zones.

FEATURES

The Main Panel has all the necessary indications required to identify the Source of the fire and take action. It also provides accurate monitoring of all modules connected to it. It Consists of a cabinets with a power supply, battery charger and space for Batteries.

LOOP WIRING

The Panel is connected to Zone modules with a 4 wire loop this consist of 2 wires for data communication and 2 wires for 24v DC supply.

INDICATION COMMON

- Alarm Dual Red LEDs.
- Supply Fault LED.
- Hooter Fault LED.
- Common Fault LED
- Zone circuit Fault LED.
- Test or Isolate LED.

PANEL SIZE

400MMX400MMX120MM

CD 32 PANEL MODEL NO

- CD 32 LC 16Z
- CD 32 LC 8Z
- CD 32 LC 24Z
- CD 32 LC 32Z

WWW.PCDFIRE.COM - Please Visit Our Website for Other Product Information

022 41205036 | 022 250003210 | 9930533861 | 9920520573 | 9987665570

sales@pcdfire.com | joseph@pcdfire.com | crispin@pcdfire.com

Head Office: Office No E1-110, Kailash Esplanade, LBS Marg, Ghatkopar West, Mumbai – 400 086
 Works: Ghatkopar Industrial Estate, B/h R-City Mall, LBS Marg, Ghatkopar West, Mumbai – 400 086

LINOVATE TECHNOLOGIES : Authorized Channel Partners For Pan India & OEM for PCD make Fire Alarm Systems